

Seismic APPLICATIONS

TETHERING

LogiQuip offers suitable items for **Seismic Applications** where site-specific approval is desired and must be approved by the Engineer of Record (EOR). The anchoring for products is different for each application. LogiQuip products can be used for a **Seismic Installation** or to **Tether** a product to the wall for secure storage. Wall and floor anchors or fasteners are not included. See local code and conditions for specifics.

TETHER

LogiQuip **TETHER** can be attached directly to the wall, floor, or strut and includes:

- TETHER-CHAIN - Grade 30 unfinished steel, 1/8 trade size, 400 lb. capacity
- TETHER-CLIP - Stainless steel grade 304, 1 7/8"D x 2"W x 1 5/8"H", 1/4" thick, 9/16" diameter hole
- TETHER-QL - Type 316 stainless steel, 3/16" thickness, 1/4" opening, 900 lb. capacity
- TETHER-SNAP - Zinc-plated steel carabiner, 1600 lb. capacity



PSTETHER

PSTETHER is required for LogiQuip ParStor units and includes:

- TETHER-CHAIN - Grade 30 unfinished steel, 1/8 trade size, 400 lb. capacity
- TETHER-CLIP - Stainless steel grade 304, 1 7/8"D x 2"W x 1 5/8"H", 1/4" thick, 9/16" diameter hole
- TETHER-QL - Type 316 stainless steel, 3/16" thickness, 1/4" opening, 900 lb. capacity
- PSTETHER-SNAP - Zinc-plated steel carabiner, 3500 lb. capacity



LIMITED 5-YEAR WARRANTY

LogiQuip products are covered by a **Limited 5-Year Warranty** from date of receipt against defect in materials or workmanship under normal use and service, excluding **Electronic Components, Cart Covers, Custom Products, LogiCell Tambour Doors, Label Holders, and Casters**. During this period, LogiQuip will, in its sole discretion, repair defects in materials or workmanship that existed when the product was received or replace the product. If the product is replaced, the new product will be warranted for the remaining term of the original product warranty period. Visit LogiQuip.com/Warranty for more details.

FLOOR & WALL MOUNTED APPLICATIONS

FLOOR-MOUNTED APPLICATION

For a floor-mounted application use the following three items:

- 43023 - Turnbuckle Galvanized, 9½", ASTM F1145, Type 1, Grade 1, work load limit 800 lb. capacity (2 of each)
- XTETHER-LANYARD - Galvanized 1/8" diameter x 12" 400 lb. capacity, coated (2 of each)
- 33125T45 - 45° Bracket (2 of each)
- TETHER-QL - Type 316 stainless steel, 3/16" thickness, 1/4" opening, 900 lb. capacity and used to connect the Turnbuckle (43023) to floor bracket (4 of each)

NOTE: It may be possible to attach the turnbuckle directly to a wire shelf and eliminate the use of the XTETHER-LANYARD

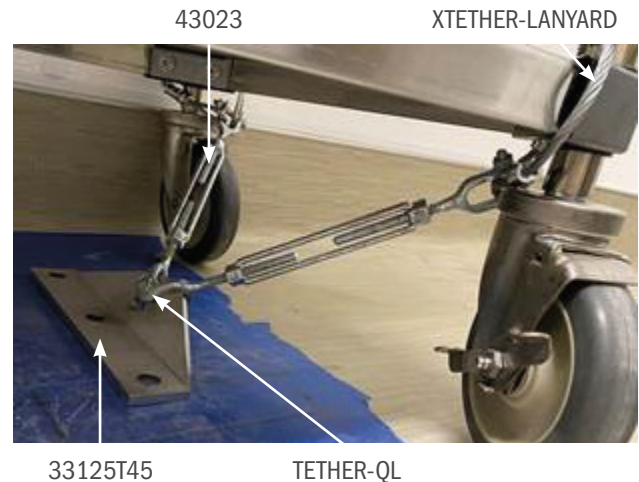

FOOTPLATE-S can be used to mount round posts to the floor and includes the following:

- Plate is 5/16" ASTM-A36, holes in plate are 9/16"
- Pipe Sleeve is ASTM A53 grade B and has 1.41" inside diameter
- Tube is .059"
- Includes 1/4" ASTM A354 GR BC bolts with hex jam nut



FOOTPLATE-S

WALL-MOUNTED APPLICATION

For a wall-mounted application use a TETHER-CLIP, TETHER-QL, and XTETHER-LANYARD.

- TETHER-CLIP - Stainless steel grade 304, 1 7/8"D x 2"W x 1 5/8"H", 1/4" thick, 9/16" diameter hole (2 of each)
- TETHER-QL - Type 316 stainless steel, 3/16" thickness, 1/4" opening, 900 lb. capacity (4 of each)
- XTETHER-LANYARD - Galvanized 1/8" diameter x 12", 400 lb. capacity, coated (2 of each)

NOTE: Unistrut Rail, Nut, and Bolt are not provided.

